



## MIXPAC™ System Approach

The MIXPAC™ System components including mixer, cartridge and dispenser are designed to fit perfectly together and to provide the best user experience.

A coded interface and separated outlets of mixers and cartridges help to prevent cross-contamination. Consequently, curing of the material within the cartridge is avoided and waste reduction is achieved. The coded interface and bayonet ring allow intuitive removal of the nose plug and easy re-installation for later use.

To complete the system, choosing an appropriate dispenser from our portfolio will ensure safe operation within the limits of the selected cartridge and mixer combination.

Working with the user-friendly and safe MIXPAC™ system will provide reproducible and repeatable results and ensures superior mixing quality.

Benefit from our application expertise and let us support you in choosing the ideal solution.

**SULZER**

# MIXPAC™ DM2X 200/400

## Manual 2-Component Multi-Ratio Dispenser



Innovation in Application



**SULZER**

# MIXPAC™ DM2X 200/400

## Exceptional dispensing with full flexibility



### Headquarters / Europe

Sulzer Mixpac Ltd  
Ruetistrasse 7  
9469 Haag  
Switzerland  
phone +41 81 414 70 00  
fax +41 81 414 70 01  
mixpac@sulzer.com  
www.sulzer.com

### USA, South America, Canada and Mexico

Sulzer Mixpac USA Inc.  
8 Willow St.  
Salem, NH 03079  
USA  
phone +1 603 893 2727  
mixpac@sulzer.com  
www.sulzer.com

### UK and Ireland

Sulzer Mixpac (UK) Ltd.  
1 Tealgate, Charnham Park  
Hungerford, Berkshire, RG17 0YT  
United Kingdom  
phone +44 1488 647 800  
coxsales@sulzer.com  
www.coxdispensers.com

### Asia Pacific

Sulzer Mixpac China  
68 Bei Dou Lu, Minhang  
Shanghai 200245  
China  
phone +86 21 6430 68 68  
mixpac@sulzer.com  
www.sulzer.com

Innovation in Application

Legal Notice: This brochure is a general presentation. The information contained in this publication is believed to be accurate and reliable but is not to be construed as implying any warranty or guarantee of performance. We waive any liability and indemnity for effects resulting from its application. Please, contact us for a description of the warranties and guarantees offered with our products. Directions for use and safety will be given separately. All information herein is subject to change without notice.  
© Sulzer 2020 / picture by Arkema\_Vincent Olivaud

APS\_AD\_MX\_FLY\_DM2X\_04-20\_en

# MIXPAC™ DM2X 200/400

## Manual 2-Component Multi-Ratio Dispenser

**Interchangeable cartridge trays and plungers**  
for quick exchange and use with other cartridge ratios

**Cast aluminum frame**  
for extended durability and stability

**Mounting hook**  
to suspend the dispenser

**Dual drive system**  
to ensure precise metering

**Ratio selector switch**  
for maximizing mix quality between  
1:1 or 2:1/4:1/10:1 ratios

**Brake release**  
easily accessible with one hand

**Ergonomic handle**  
for maximum comfort

**Cartridge release button**  
for convenient cartridge ejection



### Exceptional Dispensing

**Unique dual drive mechanism:** Synchronized movement of plunger rods enables superior metering results against comparable dispensers.  
**Rigid tool frame:** Stabilizes and supports the cartridge even for viscous products under high force applications.  
**Ratio selector switch:** Ensures superior metering quality for all ratios. Now also for 200 mL range.



### Flexibility

**The all-in-one solution:** Conversion kits\* allow 1:1, 2:1, 4:1 and 10:1 cartridges to be used in the same MIXPAC™ DM2X dispenser instead of using four separate dispensers; universal trays will also fit the pneumatic MIXPAC™ DP2X tool.  
**Optimal for demanding environments:** the DM2X is ideal for applications where sparks are not allowed and battery tools cannot be used, or where air supply is not possible.



### Ergonomics & Design

**Effortless operation:** Trigger and brake release lever are designed for jam-free operation under high force or back pressure.  
**Easily accessible controls:** Trigger and retract button can be reached with one hand by both right- and left-handed users.  
**Modern & functional design:** Improved handle ergonomics for more comfort and control; new up-to-date look & feel of the tool.

\*conversion kits sold separately

# MIXPAC™ DM2X 200/400

## Product Specifications

### DM2X 200 Specifications

- Weight: 1.60kg / 3.53lbs
- Length: 324mm / 12.7in
- Maximum thrust: 5.2kN
- Thrust ratio: 22:1
- Tool material: cast aluminum
- Cartridge capacity: 200mL
- Cartridge ratio: 1:1/2:1/4:1/10:1

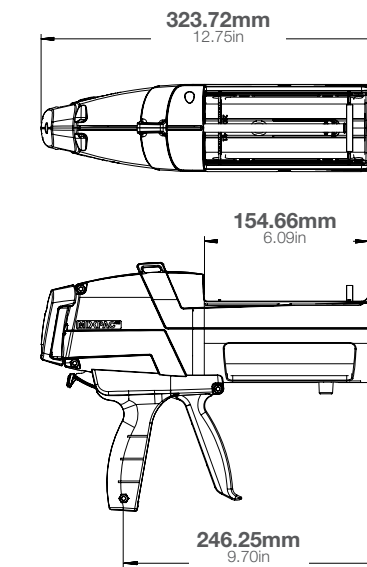

### DM2X 400 Specifications

- Weight: 1.93kg / 4.24lbs
- Length: 366mm / 14.4in
- Maximum thrust: 6.0kN
- Thrust ratio: 35:1
- Tool material: cast aluminum
- Cartridge capacity: 400mL
- Cartridge ratio: 1:1/2:1/4:1/10:1

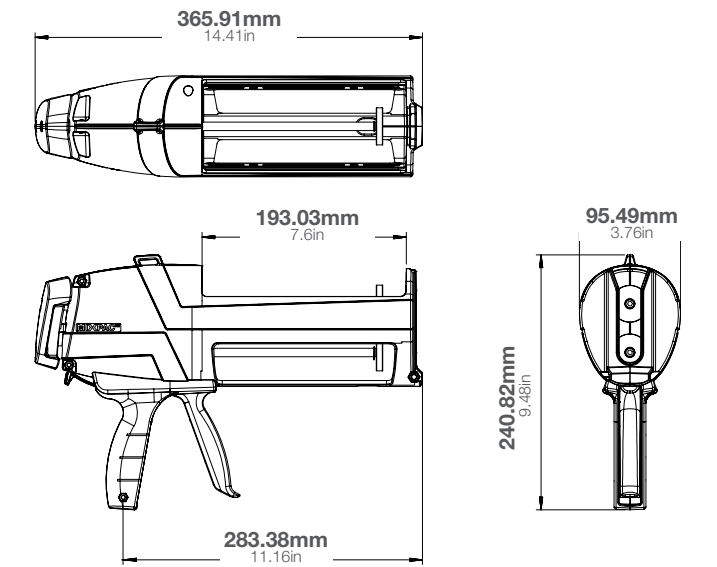

Part number:	Article number:	Ratio			
		1:1	2:1	4:1	10:1
DM2X 200-01-52-01	165803	✓	✓		
DM2X 200-04-52-01	165804			✓	
DM2X 200-10-52-01	165805				✓
<b>Conversion kits (include cartridge tray and plunger disks)</b>					
CKX 200-01-01	165834	✓	✓		
CKX 200-04-01	165835			✓	
CKX 200-10-01	165836				✓

Part number:	Article number:	Ratio			
		1:1	2:1	4:1	10:1
DM2X 400-01-60-01	165807	✓	✓		
DM2X 400-04-60-01	165808			✓	
DM2X 400-10-60-01	165809				✓
<b>Conversion kits (include cartridge tray and plunger disks)</b>					
CKX 400-01-01	165839	✓	✓		
CKX 400-04-01	165840			✓	
CKX 400-10-01	165841				✓

### Applications

The new manual MIXPAC™ DM2X 200 and DM2X 400 dispensers are ideal for a wide range of applications.



Bonding



Sealing



Solid Surface



Gap Filling



Shimming



Encapsulation

### Compatible cartridges

